

Foil

For floating engineered timber, vinyl and carpet floors



Contents

3	Preparation
4	Pre-installation testing
5	Floor sensor insulation test
6	Installing Foil
8	Installing Cushioning Overlay
9	Installing HDF Overlay Boards
10	Installing Cement Overlay Boards
11	Post installation testing
12	Floor Sensor resistance test
13	Wiring your underfloor heating thermostat
15	Commissioning your underfloor heating
16	Test results record and customer handover
17	Warranty terms and conditions

Substrate preparation

It is important to prepare the substrate properly before installing your underfloor heating. ThermoSphere foil can be installed in a floating build up, on timber or concrete sub floors.



Make sure that the sub floor is level, stable and that there is no vertical bounce/deflection.



Fix perimeter foam around the edge of the room using the self-adhesive strip or staples.

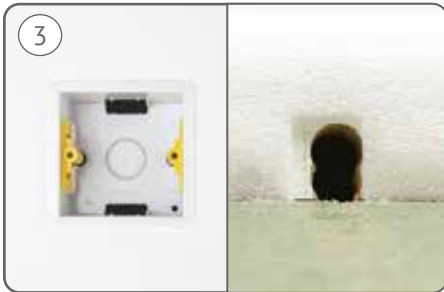

Install a back box for your thermostat and drill a 20mm hole below at the floor/wall junction.



Ensure the substrate is clean and free from any dust and debris.



Loose lay thermal insulation boards in a staggered brickwork pattern, over the whole floor. Use a sharp blade to cut the boards to fit around the perimeter, and tape together.

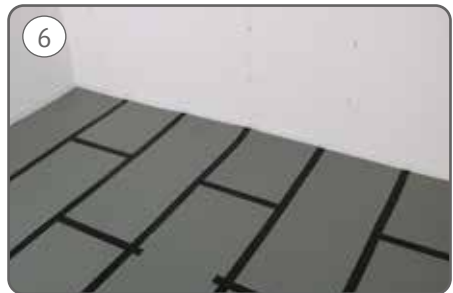

Loose lay acoustic underlay boards over the whole floor in a staggered brickwork pattern. Tape together with fixing tape.

Pre-installation testing

ThermoSphere Foil must be properly tested before and after installing, as well as once the floor finish has been laid. This ensures no damage has been done prior to or during installation.

Foil heating elements resistance tests



1 Remove the foil from the box and set your electrical test meter to Ohms mode.

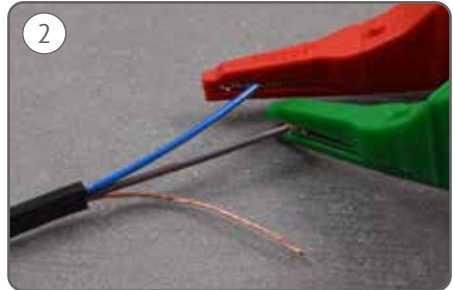

2 Connect the live and neutral wires to the separate clips of your test meter.

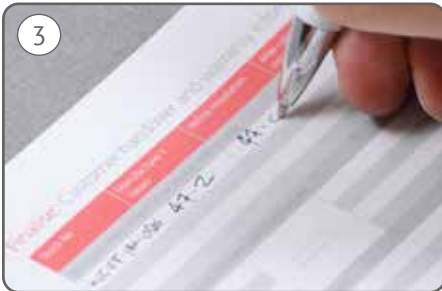

3 Record the part number and Ohms reading in the table at the back of this guide.



4 Set your electrical test meter to insulation testing mode at 500V.

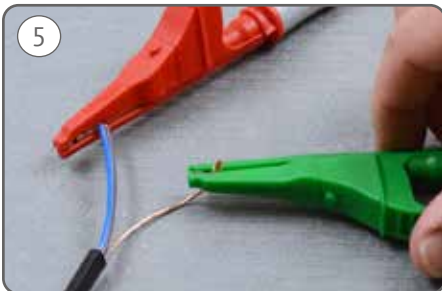

5 Connect the live and neutral to one of the clips, and the earth to the other, and press test.



6 Record the part number and Mega Ohms reading in the table at the back of this guide.



All electrical testing and connections should be done by a competent, professional electrician.

Floor sensor insulation test



Remove the sensors from the thermostat box and set your electrical test meter to Ohms mode.



Connect each cable to a separate clip on your test meter (there is no polarity).



The resistance should be close to the values in the table below, at the ambient temperature.



Record the Ohms reading in the table at the back of this guide.

Temperature °C	Resistance kΩ
0°C	32
5°C	25
10°C	20
15°C	16
20°C	12
25°C	10
30°C	8

(Floor Sensor resistance values table)

Installing Foil

Now it's time to install your Foil.



Start in a corner of the room that is close to your wiring point.



Tape the black cold tail and floor sensor cables together and feed them up to your wiring point.



Tape your floor sensor(s) in position in a cut out in the underlay boards. Stagger multiple sensors.



Roll the foil out until you get to the end of the room.



Expose the heating cables and carefully cut the foil.



WARNING! Do not cut the heating cable!



Flip the foil over and continue rolling it out. Repeat this until the whole floor is covered.



The entire heated area should be covered with the foil, leaving approximately 100mm around the edge of the room.

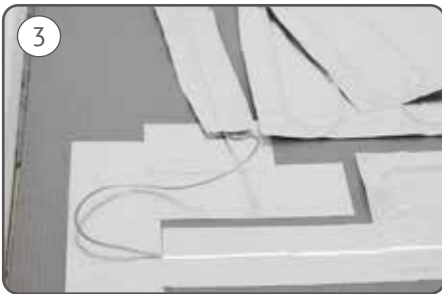

Cut the cable from the foil and arrange it in awkward areas. Minimum spacing 50mm.

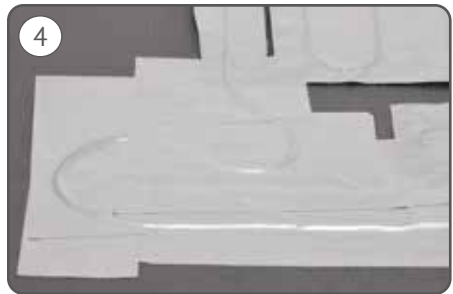

Use 2 layers of foil tape, under and over the cable, to fix it in position.



WARNING! Do not cover the heating cable with fixing tape! It can cause over heating and will void your warranty!



The cold tail can be taped in a channel cut into the underlay boards. This helps to keep the final floor flat.

Installing Cushioning Overlay

Cushioning Overlay creates a single protective layer over the top of your Foil system. This protects against moisture, abrasion and reduces impact sound.



1 Start in the corner of the room and roll the Cushioning Underlay over the whole floor.



2 Stick parallel runs together using the self adhesive strip on each run of overlay.



3 Make sure the runs are stuck together properly and laid perforated side up.



4 Repeat these steps to cover the whole floor, including any unheated areas.



5 Follow the manufacturer's instructions to lay the engineered timber flooring.



6 Cover the whole floor area with engineered timber boards.

Installing HDF Overlay boards

HDF Overlay Boards must always be installed over Cushioning Overlay before laying carpet or vinyl floor finishes, or anything other than engineered timber that is at least 10mm thick. It provides a flat surface, prevents cables from being seen or felt underfoot and protects the integrity of tongue and groove joints.

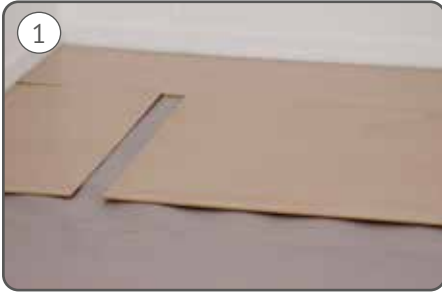

Start in the corner of the room and lay the base board (4mm) in a staggered brick work pattern.



Cut boards with a sharp blade, but don't cut boards over the foil heating mat!



Cut boards over another board to avoid accidentally cutting the heating cable.



Remove the protective plastic from the top and bottom boards.



Lay the top board (3mm) over the base boards in a staggered brickwork pattern, perpendicular to the pattern of the base boards.



Repeat the steps to cover the whole floor and activate the adhesive using a rubber mallet.

Installing Cement Overlay boards

Cement overlay boards are installed over Cushioning Overlay to provide a robust layer to adhere bonded finishes such as LVT or engineered timber boards to.



Start in the corner of the room and lay the base board (6mm) in a staggered brick work pattern and remove the protective plastic.



Lay the top boards in a staggered brickwork pattern, perpendicular to the pattern of the base boards.



Repeat the steps to cover the whole floor and activate the adhesive using a rubber mallet.

Post installation testing

To make sure there's been no damage during installation, you need to repeat the resistance and insulation resistance tests for your heating cable.

Heating Cable resistance test



Get your test meter, turn it on and set to ohms.



Connect the neutral (blue) wire to one clip.



Connect the live (brown) wire to the other clip.



Check your meter reading, it should be within +10/-5% tolerance of the values found on the product labels.



Note the readings in the customer handover document for their warranty registration.



All electrical testing and connections should be done by a competent, professional electrician.

Floor Sensor resistance test



Get your test meter, turn it on and set to ohms.

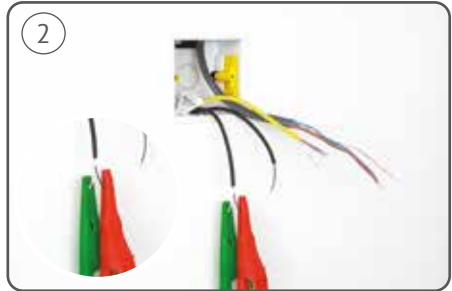

Connect one cable to each clip. The cables have no polarity.



The resistance value should be close to the values in the table below, for the ambient temperature.



Record both sensors' resistance result.

Temperature °C	Resistance kΩ
0°C	32
5°C	25
10°C	20
15°C	16
20°C	12
25°C	10
30°C	8

(Floor sensor resistance values table)

Wiring your underfloor heating thermostat

The next steps show how to wire a ThermoSphere BT21. Make sure to check your specific thermostat's instructions as wiring varies depending on your thermostat model.



To ensure your safety and to protect the thermostat, isolate the circuit from mains power.

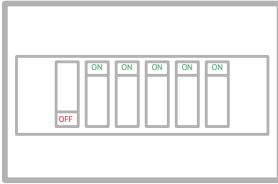

Fuse Box

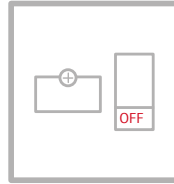

Fused Switch

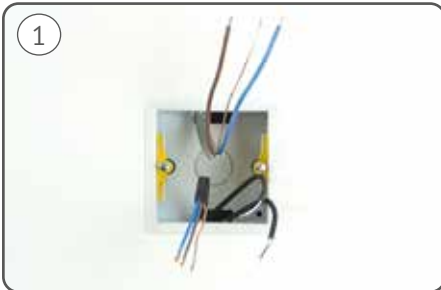
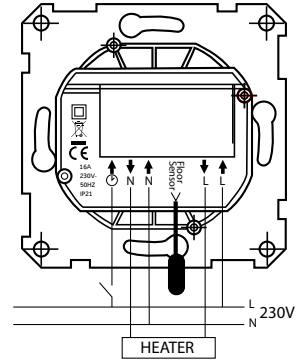

You should have 4 cables at your wiring point. 1. 230V supply 2. Heating cold tail 3. Floor Sensor 4. Spare Sensor



Terminate the spare floor sensor with a terminal block and tuck into the back box.



Insulate the supply and cold tail earths and connect them with a terminal block.



Connect the wires to the correct terminals on the back of the thermostat.



Fit the thermostat to the back box with the supplied screws



Add the Thermostat fascia. Final electrical connections must be carried out by a competent electrician!



It is not recommended to heat floors to temperatures above 27°C. Always consult your floor finish manufacturer to check suitability for use with underfloor heating and maximum recommended temperature settings.



Do not lay any insulating objects including but not limited to rugs, mats, dog beds, furniture that does not have feet or bean bags, over a heated floor. This can result in overheating, damage to the floor finish and object, as well as potential cable damage or damage to the floor layers.

Commissioning your underfloor heating

Now you've installed your ThermoSphere Underfloor Heating, it's important to follow the next few steps to ensure your floors adjust gradually to your underfloor heating and avoid thermal shock.

During commissioning mode, your underfloor heating self learns how long the heat up time is to get to the set temperature. This results in rooms at the right temperature, exactly at the right time. If you've programmed your heating on for 8am, it won't start then, it will already be at your desired temperature at 8am.

- 1 Turn on the electrical power. Ensure heating is off by setting a low temperature eg: 5°C.
- 2 Set thermostat to floor sensing.
- 3 Set your floor sensor limit to 27°C.
- 4 Turn the temperature to 2°C over measured floor temperature. I.e: if floor temperature is showing 16°C, increase set temperature to 18°C.
- 5 Leave for the first 24 hours and let the floor reach and maintain that temperature.
- 6 Increase the temperature on your thermostat by a maximum of 2°C every 24 hours, until you've reached your desired floor temperature. Note: max 27°C.
- 7 You can now switch your thermostat to ambient temperature setting (with floor limit) to maintain room temperature.

Test results record and customer handover

Installer: The installer must complete the full test procedure and complete this page in full before giving it back to the home owner to keep in case of a warranty claim.

Homeowner: Use this information to register your Lifetime Warranty at www.thermosphere.com. You must keep this document and proof of purchase for your records in case of a warranty claim.

Stock No	Manufacturer's Values	Before installation	After cable installation	After tile installation
Resistance measurement of the electric heating cable				
Insulation resistance test (two conductors and earth braid)				
	Greater than 499 MΩ			
Floor temperature sensor test				

Installer details	
Name:	Address:
Company:	Postcode:
Email:	Part P number:
Phone:	Date & Signature:

Warranty terms and conditions

Thermogroup Ltd (T/A ThermoSphere) will repair or, if necessary, at its sole discretion, replace a faulty heater, which falls within the Warranty Periods and Territory specified below, subject to the warranty conditions and the warranty exclusions. Warranty Period within the United Kingdom is 25 years from the date of purchase by the consumer as defined by the Competition and Consumer Act 2010. ThermoSphere Underfloor Heating is covered by a Lifetime Warranty when the installation is registered online with ThermoSphere and a Lifetime Warranty Confirmation has been sent, in writing, by ThermoSphere.

Our goods come with guarantees that cannot be excluded under the UK Consumer Law. You are entitled to a replacement or refund for a major failure that occurs because of a manufacturing fault or manufacturing defect. It is the responsibility of the end user to provide proof of purchase within the Territory, to initiate a warranty claim.

WARRANTY CONDITIONS

This warranty is applicable only for ThermoSphere Foil (herein referred to as "The heating system").

The heating system must be installed in accordance with the ThermoSphere Installation Instructions, to be supplied with the heating system and/or available as a digital download, and in accordance with all relevant statutory and local regulations of the Territory in which the heating system is installed.

Where a failed component or heating system is replaced under warranty, the balance of the original warranty period will remain effective. The replaced part or heating does not carry a new warranty.

Where a failed component is replaced or repaired under warranty, ThermoSphere will incur costs associated with shipping and repair at its sole discretion, if the unit is installed within the UK. If the unit is outside the UK, the associated costs are the responsibility of the owner.

Where the heating system is installed in a position that does not allow safe, ready access, the cost of accessing the site safely, including the cost of additional materials handling and/or safety equipment, shall be the owner's responsibility.

The warranty only applies to the heating foil and, therefore, does not cover any electrical or flooring parts supplied by others that are not an integral part of the ThermoSphere heating system, for example but not limited to; tile adhesive, floor coverings, electrical accessories, thermostats and contactors.

The benefits of this warranty are in addition to other rights and remedies of the consumer under laws in relation to the goods and services to which the warranty relates.

PROCEDURE FOR HONOURING WARRANTY

To initiate a claim for a warranty against defects, the consumer shall contact: Thermogroup Ltd T/A ThermoSphere, Bridge House, Pattenden Lane, Marden, Kent, TN12 9QJ, United Kingdom. hello@thermosphere.com. 0800 0195899.

The process will then follow the ThermoSphere Product Warranty Flow Chart to assess whether the product is under warranty.

WARRANTY EXCLUSIONS

Repair and replacement work will be carried out as set out in the ThermoSphere warranty. However, the following exclusions may cause the ThermoSphere warranty to become void and may incur a service charge and/or cost of parts:

Accidental damage to the heating system or any component, including: Acts of God; failure due to misuse, abuse, fire or flood damage; incorrect installation; damage as the result of transportation, removal or storage; attempts to repair the heating system other than by a ThermoSphere Accredited Service Agent, the ThermoSphere Service Department or a repairer not approved by ThermoSphere.

Where it is found there is nothing wrong with the heating system; where the complaint is related to circumstances where there is no power supply due to faulty electricians; where faults are related to the electrical supply or incorrect installation and not the heating system or heating system components; where there is a failure of electricity supply; where the supply of electricity does not comply with relevant standards, codes or acts, ThermoSphere may then charge the consumer a nominal service charge if inspection reveals no fault with the heating system.

Where the heating system or heating system component has failed directly or indirectly as a result of incorrect cable installation, overheating due to incorrect cable placement, incorrect treatment of the cold tail joint or end termination, failure to encase the entire heated section of the cable as well as the cold tail connection and element in a full bed of tile adhesive or levelling compound, insulating the heating cables from above with permanent fixtures, sanitary ware, furniture or carpets/rugs.

Where the heating system is installed and/or located in a position or fashion that does not comply with the ThermoSphere Installation Instructions or relevant statutory requirements, causing the need for major dismantling or removal of cupboards, doors or walls, or use of special equipment to repair the heating system.

Subject to any rights you have under UK Consumer Law or other statutory provisions to the contrary, this warranty excludes any and all claims for damage to floors, furniture, carpets, walls, foundations, building fabric, possessions or any other consequential loss either directly or indirectly due to damage from the heating system, workmanship or other.

Draw your layout plan here

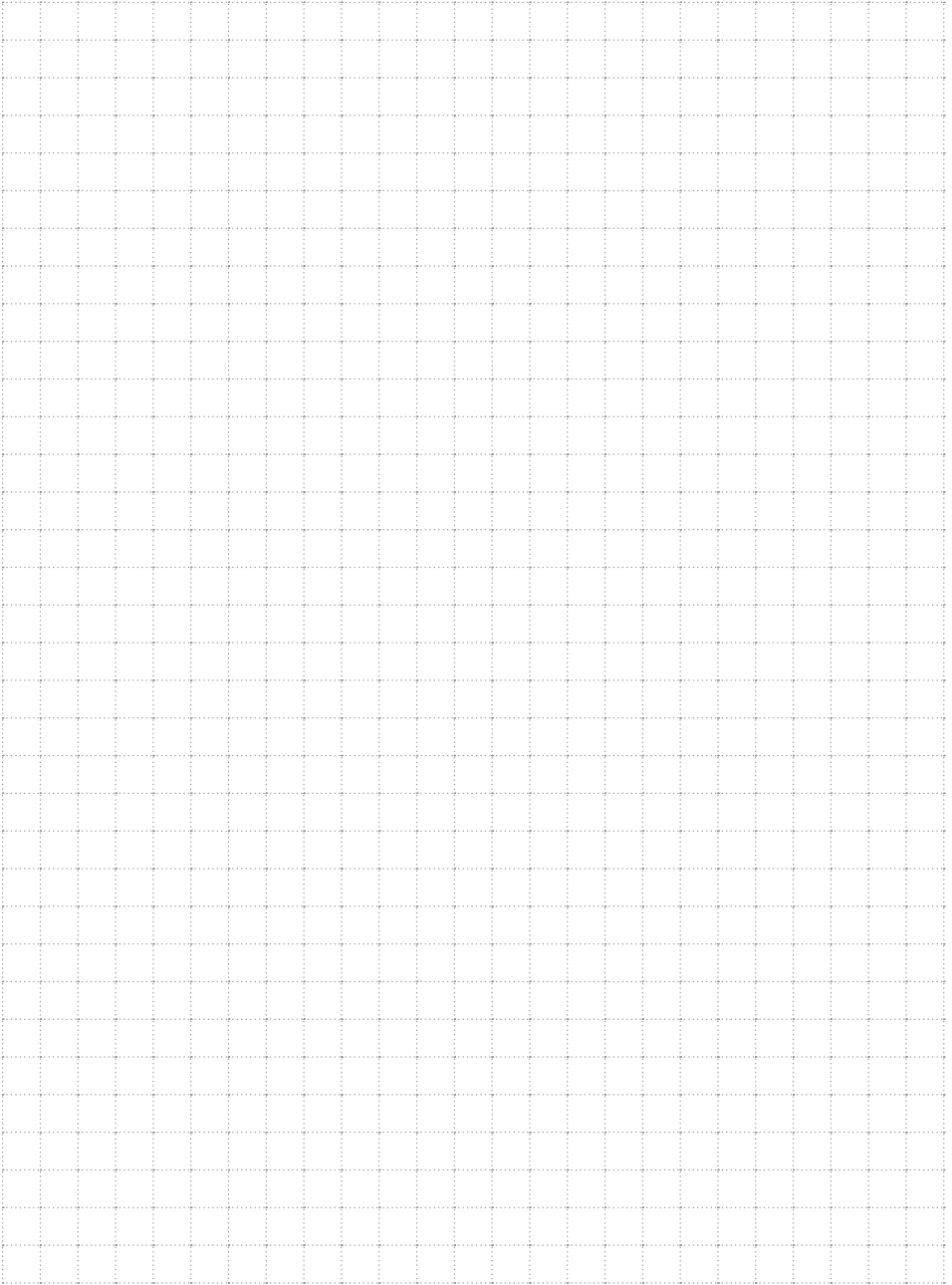

Notes

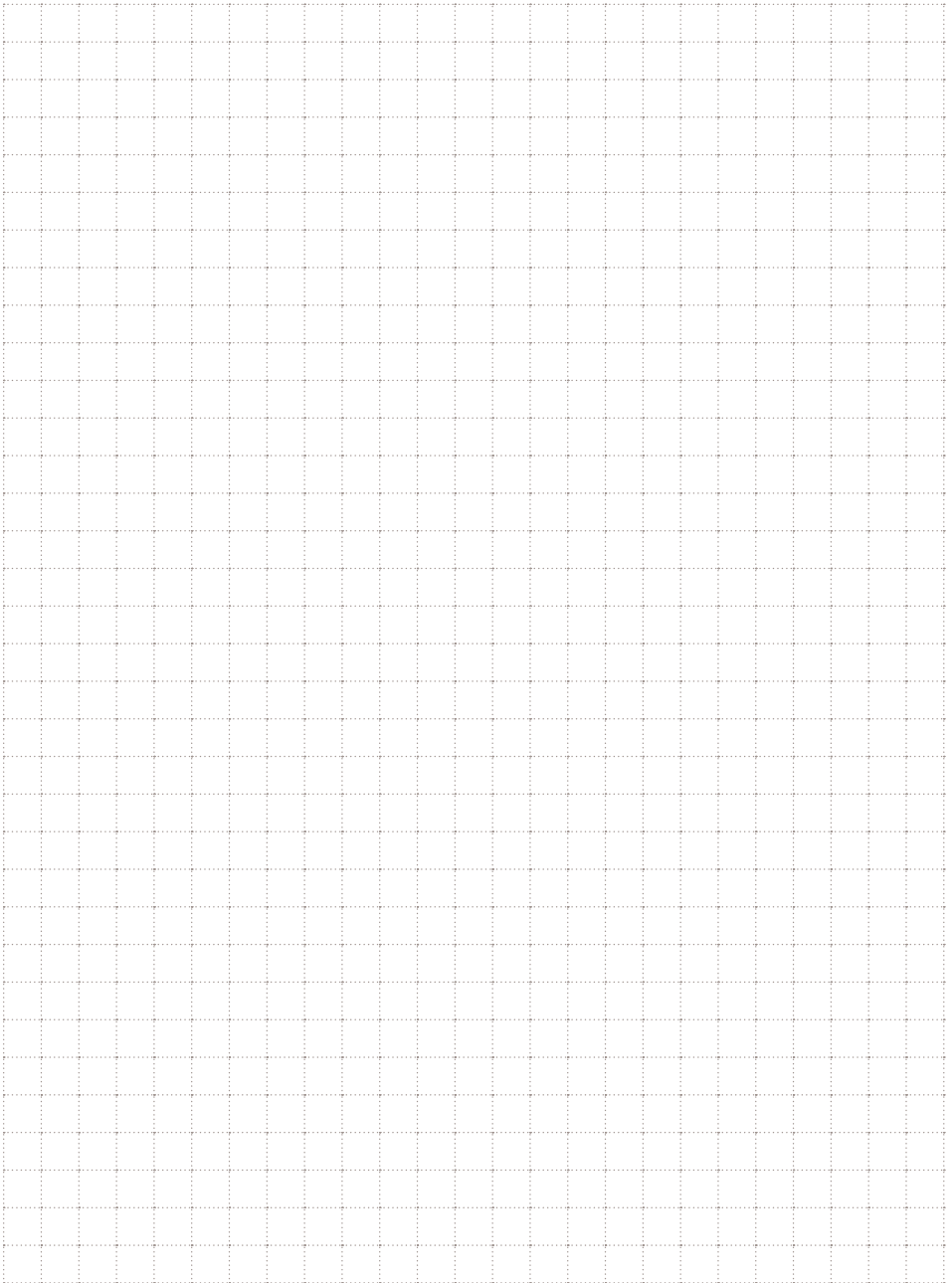

ThermoSphere
Bridge House
Pattenden Lane
Marden
Kent
TN12 9QJ
UNITED KINGDOM

www.thermosphere.com

support@thermosphere.com

+44 (0) 1622 689 440



Find us on LinkedIn
Search "ThermoSphere"



Check out our Youtube channel
Search "ThermoSphere underfloor heating"



Find us on Instagram
Search "ThermoSphere"



**MADE IN
BRITAIN**[®]

ThermoSphere manufactures underfloor heating products in Marden, Kent. However, some accessory products are imported from trusted sources. To make it easy to tell where a product is from you'll find the country of origin stated on all product data sheets. Please visit our website for more information.